

86 Old Church Road
Chingford
E4 8BX

T: 0208 524 7444
www.kings-group.net



Drysdale Avenue, E4 7NL



£500,000 Freehold

*** CHAIN FREE ***

Kings Group are delighted to offer for sale this well-presented three-bedroom detached chalet bungalow, situated on the ever-popular Drysdale Avenue in Chingford. Offered to the market with no onward chain, this property is ideal for families seeking spacious accommodation in a highly desirable location.

The property features a generous living/dining room, a contemporary fitted kitchen, a modern ground floor bathroom, and the added convenience of a first-floor WC with wash hand basin. Further benefits include gas central heating, double glazing throughout, a private rear garden, and off-street parking.

For families, the property falls within the catchment area for the highly regarded Yardley Primary School, making it an excellent choice for those looking to settle in the area.

Ideally positioned within easy reach of Station Road, North Chingford, residents can enjoy a wide selection of independent shops, cafés, restaurants, bars, and supermarkets, including Co-op and Tesco Express. Chingford Overground Station provides direct links into London Liverpool Street, with convenient connections to the Victoria Line via Walthamstow Central.

Nature lovers will appreciate the close proximity to Epping Forest, offering extensive woodland walks, cycling routes, and open green spaces to enjoy throughout the year.

To arrange a viewing, contact Kings Group on 0208 524 7444!

PORCH

LIVING ROOM 18'3 x 18'1

KITCHEN 11'10 x 8'2

BATHROOM

BEDROOM ONE 9'7 x 8'9

LANDING

WC

BEDROOM TWO 11'8 x 10'7

BEDROOM THREE 10'0 x 9'10

SHED 12'6 x 6'0

DISCLAIMER

1. MONEY LAUNDERING REGULATIONS: Intending purchasers will be asked to produce identification documentation at a later stage and we would ask for your co-operation in order that there will be no delay in agreeing the sale.
2. General: While we endeavour to make our sales particulars fair, accurate and reliable, they are only a general guide to the property and, accordingly, if there is any point which is of particular importance to you, please contact the office and we will be pleased to check the position for you
3. The measurements indicated are supplied for guidance only and as such must be considered incorrect.
4. Services: Please note we have not tested the services or any of the equipment or appliances in this property, accordingly we strongly advise prospective buyers to commission their own survey or service reports before finalising their offer to purchase.
5. References to tenure of a property are based upon information supplied by the vendor. The agent has not had sight of the title documents, a buyer is advised to obtain verification from their solicitor.
6. THESE PARTICULARS ARE ISSUED IN GOOD FAITH BUT DO NOT CONSTITUTE REPRESENTATIONS OF FACT OR FORM PART OF ANY OFFER OR CONTRACT. THE MATTERS REFERRED TO IN THESE PARTICULARS SHOULD BE INDEPENDENTLY VERIFIED BY PROSPECTIVE BUYERS OR TENANTS. KINGS GROUP NOR ANY OF ITS EMPLOYEES OR AGENTS HAS ANY AUTHORITY TO MAKE OR GIVE ANY REPRESENTATION OR WARRANTY WHATSOEVER IN RELATION TO THIS PROPERTY.



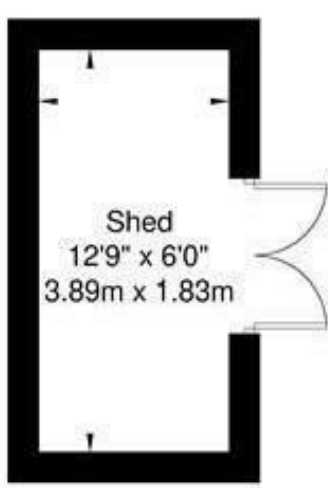

Garden
25'0" x 23'0"
7.62m x 7.01m

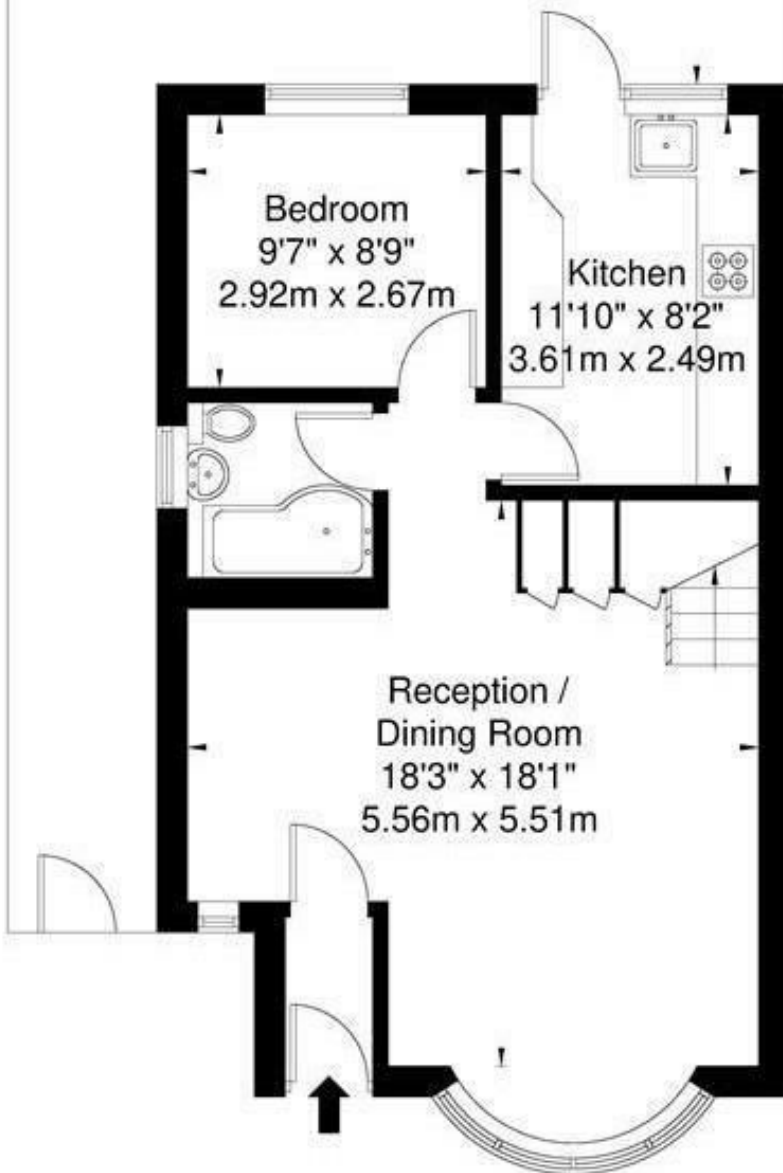

Ground Floor

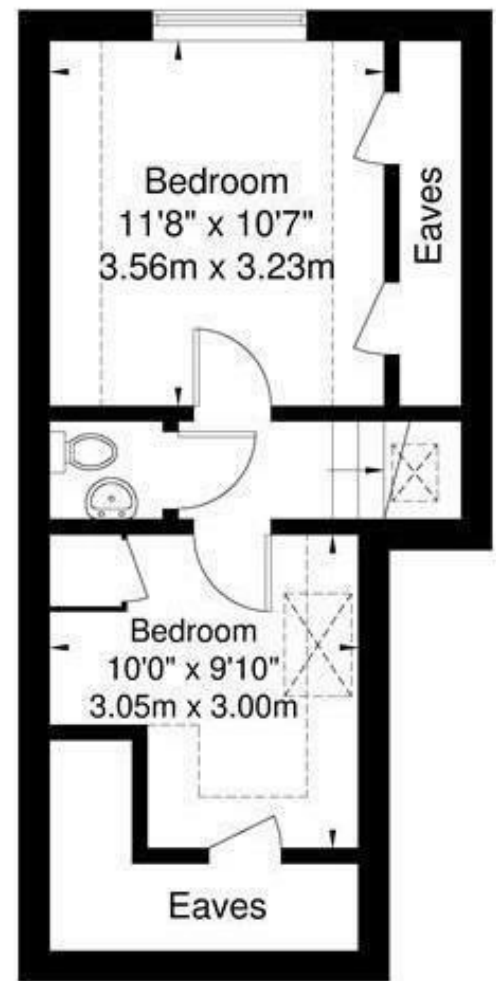

First Floor

For Illustration Purposes Only - Not To Scale

This floor plan should be used as a general outline for guidance only and does not constitute in whole or in part an offer or contract. Any intending purchaser or lessee should satisfy themselves by inspection, enquiries and full survey as to the correctness of each statement. Any areas, measurements or distances quoted are approximate and should not be used to value a property or be the basis of any sale or let.

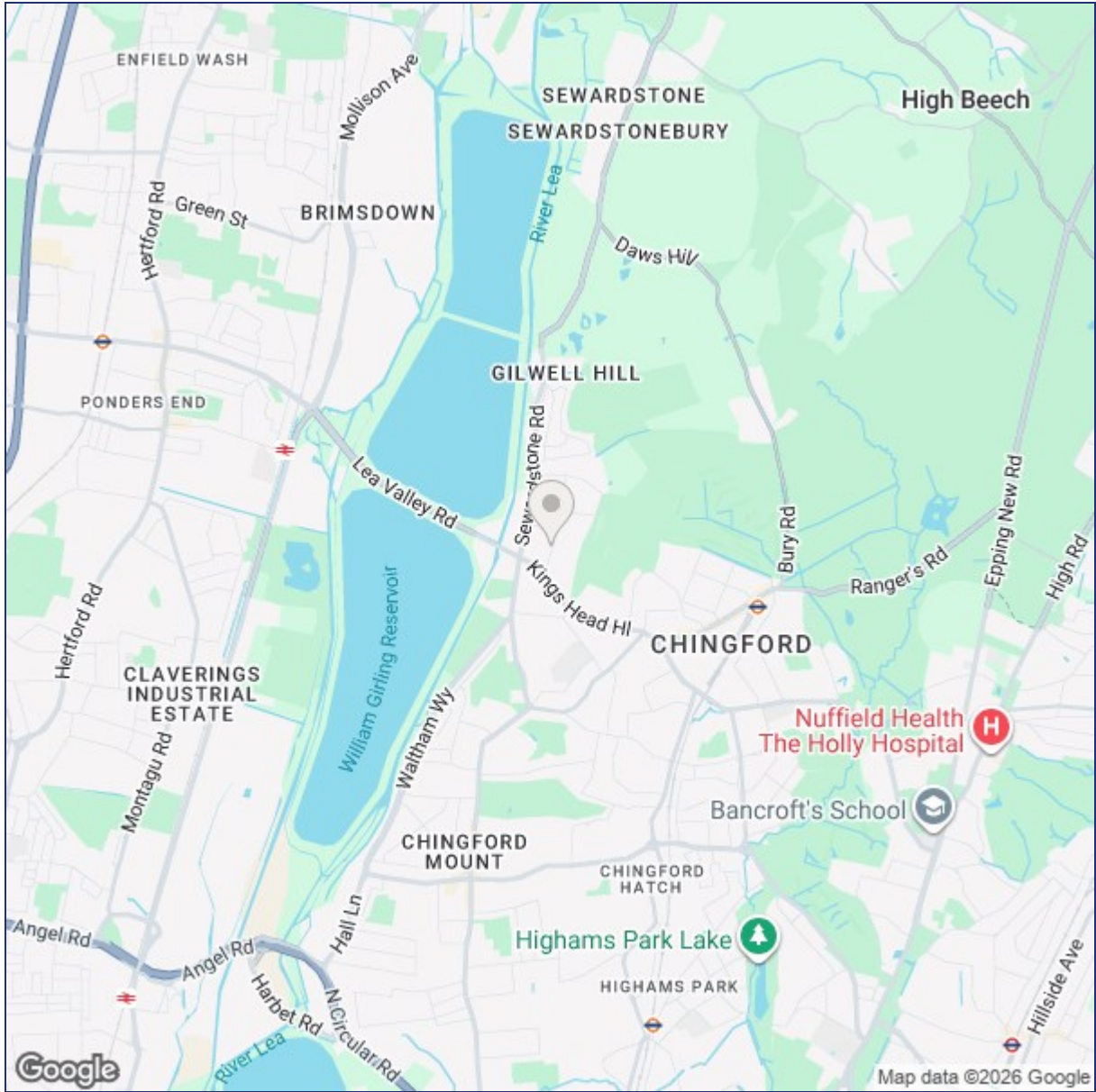

Energy Efficiency Rating	
Current	Potential
Very energy efficient - lower running costs	
(92 plus) A	81
(81-91) B	
(69-80) C	
(55-68) D	
(39-54) E	
(21-38) F	
(1-20) G	
Not energy efficient - higher running costs	
69	
EU Directive 2002/91/EC	

Environmental Impact (CO ₂) Rating	
Current	Potential
Very environmentally friendly - lower CO ₂ emissions	
(92 plus) A	81
(81-91) B	
(69-80) C	
(55-68) D	
(39-54) E	
(21-38) F	
(1-20) G	
Not environmentally friendly - higher CO ₂ emissions	
81	
EU Directive 2002/91/EC	

("These details are correct at time of going to press").

THE PROPERTY MISDESCRIPTIONS ACT 1991. The agent has not tested any apparatus, equipment, fixtures or services and so cannot verify that they are in working order, or fit for the purpose. References to the Tenure of a property are based on information supplied by the vendor. The agent has not had sight of the Title documents. A buyer is advised to obtain verification from their Solicitor or Surveyor.

